

NO WELDING OR PAINTING REQUIRED!

#4190 INSTA CORNER CASTING ADAPTER

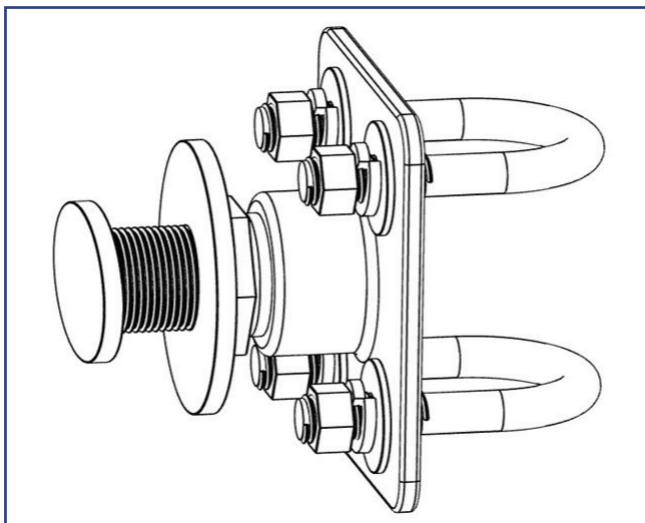

#4190 INSTA CORNER CASTER ADAPTER DESCRIPTION:

The INSTA Corner Caster Adapter is a quick connect and disconnect **NO WELD** adapter for mounting various structures and fixtures to shipping container corner castings.



SPECS

- Weight 3.00 lbs / 1.36 kg
- Aluminium Construction
- Mounting Hardware Included



OTHER OPTIONS

- #4191 INSTA Container Solar Lighting System

CORNER CASTING ADAPTER



SOLAR LIGHT
SYSTEM



FOR SHIPPING CONTAINERS



INSTA Container Modifications is a proud charter member of the National Portable Storage Association (NPSA).

WARNING - All products that require installation or fabrication should never be done until you have the product in hand to take exact measurements. While every attempt is made to make sure product specifications are accurate, there is the possibility the products have been updated or a small variance between production made the measurement off. Installation of products may require some fabrication experience, and in no way does warranty cover installation mistakes.