

NO WELDING OR PAINTING REQUIRED!

#6200 INSTA TWIST LOCK

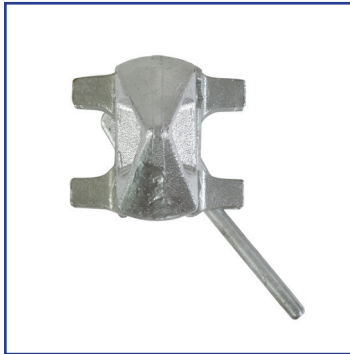

#6200 INSTA TWIST LOCK DESCRIPTION:

The INSTA Twist Locks are designed to connect two shipping containers vertically. Keep your shipping containers firmly secured with Insta Twist Locks. Built to match standard ISO container corner castings, each twist lock includes locating cones on both ends for proper alignment, along with a handle that allows for fast locking and release.

Although containers are designed to be stacked, Insta Twist Locks are a critical safety measure in environments like construction sites, storage facilities, and temporary installations. They're especially important in situations where movement could occur due to strong winds, impacts, or uneven ground, helping ensure containers stay stable and safely in place.

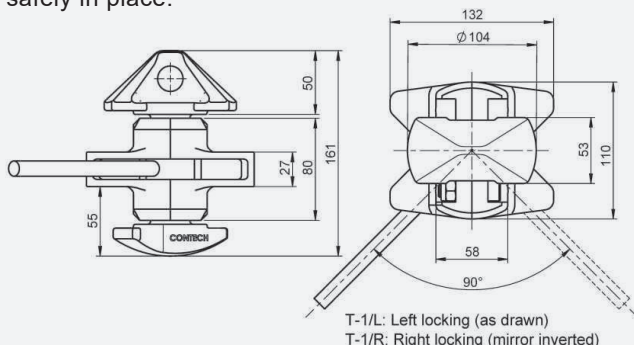

SPECS

- Weight 10.25 lbs. / 4.65kg
- Safe working load in tension 56,000 lbs
- Safe working load in shear 47,400 lbs
- Min breaking load in tension 112,400 lbs
- Min breaking load in shear 94,800 lbs



FEATURES

- High quality casted steel construction
- Hot-dipped galvanized finish
- Double-ended design to connect two containers



RELATED PRODUCTS

- 6202 Deck Mount Twist Lock
- 6203 Retractable Twist Lock
- 6204 Hanging Stacking Cone
- 6208 Container Bridge Fitting
- 6210 Container Corner Castings
- 6212 Container Lifting Lug



INSTA Container Modifications is a proud charter member of the National Portable Storage Association (NPSA).

WARNING - All products that require installation or fabrication should never be done until you have the product in hand to take exact measurements. While every attempt is made to make sure product specifications are accurate, there is the possibility the products have been updated or a small variance between production made the measurement off. Installation of products may require some fabrication experience, and in no way does warranty cover installation mistakes.